

Material: Messing, vernickelt
 Dichtmaterial: Buna-N
 Arbeitsdruck: max. 18,0 bar

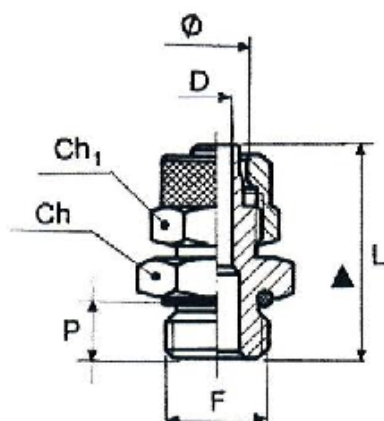

11.114-8

Gerade Einschraubverschraubung, Außengewinde zylindrisch mit O-Ring

Art.-Nr.	Ø	F	Ch	Ch1	Gewinde Ch1	P	L	D	O-Ring
11.105-4	4/2	M5	9	9	M 7x0,5	4,0	23,0	1,5	4x1,5
11.105-5	5/3	M5	8	8	M 7x0,75	4,0	20,0	2,0	-
11.105-6	6/4	M5	9	9	M 8x0,5	4,0	23,0	2,7	4x1,5
11.118-5	5/3	G 1/8	14	8	M 7x0,75	6,0	23,0	2,0	-
11.118-6	6/4	G 1/8	15	12	M 10x1	6,0	25,0	3,0	7,66x1,78
11.118-8	8/6	G 1/8	15	14	M 12x1	6,0	25,0	5,0	7,66x1,78
11.118-10	10/8	G 1/8	14	16	M 14x1	6,0	27,0	6,8	-
11.114-6	6/4	G 1/4	18	12	M 10x1	8,0	27,0	3,0	10,82x1,78
11.114-8	8/6	G 1/4	18	14	M 12x1	8,0	27,0	5,0	10,82x1,78
11.114-10	10/8	G 1/4	18	16	M 14x1	8,0	29,0	6,8	10,82x1,78
11.138-6	6/4	G 3/8	19	12	M 10x1	9,0	29,0	3,0	-
11.138-8	8/6	G 3/8	21	14	M 12x1	9,0	29,0	5,0	14,0x1,78
11.138-10	10/8	G 3/8	21	16	M 14x1	9,0	31,0	6,8	14,0x1,78
11.138-12	12/10	G 3/8	21	19	M 16x1	9,0	33,0	8,5	14,0x1,78
11.112-6	6/4	G 1/2	24	10	M 10x1	10,0	30,0	3,0	17,13x2,62
11.112-8	8/6	G 1/2	24	12	M 12x1	10,0	30,0	5,0	17,13x2,62
11.112-10	10/8	G 1/2	26	16	M 14x1	11,0	33,0	6,8	17,13x2,62
11.112-12	12/10	G 1/2	26	19	M 16x1	11,0	35,0	8,5	17,13x2,62